

# "A Clear View"

## Into Construction & Operation

### 2H30-[ ] Pressure Regulator

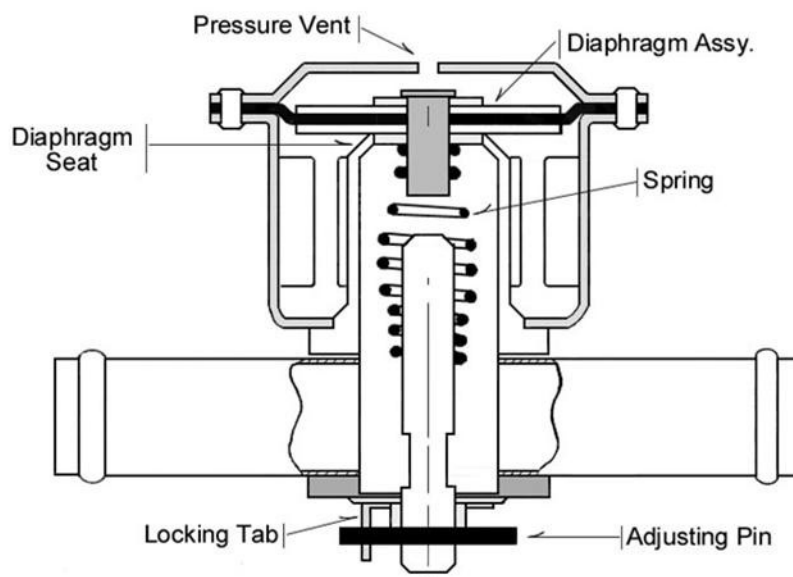

#### Description

The 2H30-[ ] pressure regulator is designed to maintain desired pressure to the aircraft gyro instruments via a spring-loaded diaphragm. All 2H30 valves operate in the same basic manner, with model number variations ( - [ ] ) denoting number of connecting tubes, tube diameter and/or pressure adjustment range.

#### Operation

Air pump pressure enters the valve center body applying pressure to the bottom of the regulator diaphragm and rivet assembly. With the regulator spring tension preset for 4.7" to 5.2" Hg. (2-1/3 to 2-2/3 psi), any increase in pressure from the air pump will force the diaphragm upward off its seat, allowing the excess air pressure to vent overboard.

A pressure vent hole located at the center of the valve cover will vent all air displaced by the rising diaphragm.

Increasing spring tension by turning the adjustment screw will result in greater system pressure in the valve body and higher "back pressure" on the air pump. The result will always be shorter pump life.

#### **NOTE:**

**The gyro instrument pressure gage does not monitor air pump pressure !**

#### Common Problems

A damaged or deteriorated diaphragm, loose cover, or broken spring will result in loss of system pressure adjustment.

Loss of pressure regulation caused by carbon particles lodged under the valve diaphragm is a common occurrence following in flight air pump failure.

#### **Remember!**

**If the regulator needs adjustment...  
Your system needs maintenance**